

KEY FEATURES

- Mandrel-free RL testing
- 4 Single-mode lasers built-in
- Available for single-mode and multimode
- EF compliant for multimode
- Bidirectional or unidirectional testing

APPLICATIONS

- Passive optical components design and validation
- Patchcord and cable assembly certification
- Compliance testing

COMPLIANCE

- Conforms to GR-326-CORE, GR-1435-CORE, GR-910-CORE, GR-1209-CORE, GR-2866-CORE, Verizon FOC

IN THE SYSTEM

- RL1 Automated Return Loss Meter
- Dual SX1 Switches
- EOTS software

Product Description

The EOTS Environmental Optical Test System provides a fully integrated solution for long-term testing of optical devices. At the core of the EOTS is an RL1 Automated Return Loss Meter for fast and accurate IL & RL measurements. The SX1 switches used in the EOTS have a repeatability of $\pm 0.005\text{dB}$ allowing for reliable long term measurements. With its capability to measure changes in Insertion Loss (IL) and mandrel-free Return Loss (RL) of up to 320 channels, the EOTS is the perfect solution to perform compliance testing of devices being stressed in environmental simulations.

Flexible Software

The free EOTS Environmental Optical test software simplifies your long-term compliance testing. Tests can easily be setup to monitor IL & RL variation on a real-time graph. Results can be exported for hassle-free compliance analysis.



Self-calibration

The EOTS Environmental Test System does not need to be sent back to JGR for annual calibration. The self-calibration feature built inside the RL1 provides step-by-step instructions and generates a calibration report thereby minimizing down-time and assuring measurement reliability.

Customizable setup

Results can be exported for hassle-free compliance analysis. The EOTS is made up of an RL1 Automated Return Loss Meter and dual SX1 switches, both of which can be benchtop or equipped with rack mounts. If you prefer to have your equipment in a rack, or you prefer to have your equipment on a bench, we can help you optimize your setup stability and reliability.



Ordering Scheme & Instructions

1 - Configure RL1 meter

Single-mode version

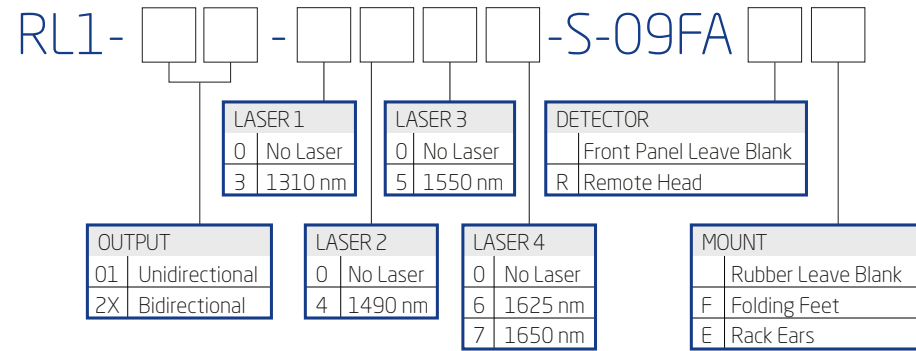

Multimode version

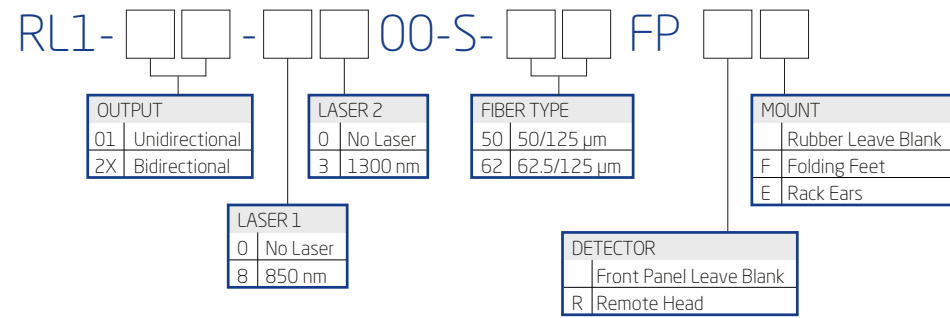

2 - Configure SX1 switches *2 switches required

Switch chassis

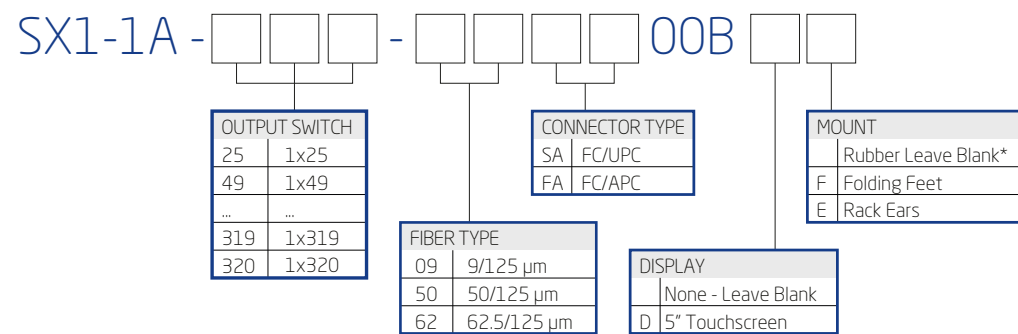

*Rubber bezel only available in 2U half rack

3 - Add accessories

Slide detector adapters

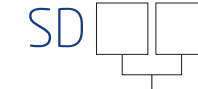

TYPE					
00	Cap	14	MU	20	DA113 Barrel
01	FC	15	E2000	21	BFA3000 Barrel
02	ST	16	Universal 2.5.	26	Universal 1.6
03	SC	17	MTP/MPO	34	LC Duplex
04	Universal 1.25.	18	LC	35	Optitap
12	MT	19	MT-RJ	37	MXC
38	MTPO/MPO-16				
64	CS				
67	SN				
68	MDC				

More detector adapters available upon request. See more details on pg 110.

2U Rack Short ear
2U-RACK-SHORT-EAR



2U Rack Long ear filler plate
2U-RACK-LONG-EAR



2U chassis connector plate
2U-CONNECTOR-PLATE



2U rubber bezels
2U-BEZEL



Flip-out Feet
CHASSIS-FEET



Optical/Electrical Specifications

Parameter	Specification	
	Single-mode	Multimode
Fiber Type (μm)	9/125	50/125 and/or 62.5/125
Encircled Flux Standard	N/A	IEC 61280-4-1
Operating Wavelengths (nm)	1310 / 1490 / 1550 / 1625 / 1650	850 / 1300
Return Loss Range (dB)	30 to 85	10 to 60
Return Loss Accuracy (dB)	± 1.0 (30 to 70)	± 1.4 (10 to 30)
	± 1.3 (70 to 75) ¹	± 1.9 (30 to 40)
	± 2.9 (75 to 80) ²	± 2.2 (40 to 43)
	± 3.9 (80 to 85) ²	± 4.7 (43 to 60)
Detector Type	Wide Area Integrating Sphere	
Insertion Loss Accuracy (dB)	± 0.03 (<5 dB loss)	
	± 0.15 (≥5 dB loss)	
Testing Time (s)		
Standard Mode	<5 per wavelength	
Fast Mode	<1.5 per wavelength	
Cable Assembly Length (m)		
RL mode	< 4000 ³	500 ³
RL _{total} mode	< 4000 ⁴	N/A
Remote Interface	Ethernet / USB	
Display	5" touch screen	
Input Voltage	100 - 240 V AC, 50 - 60 Hz	
Power Consumption (VA)	60 maximum	

Notes:

¹ add ±0.4 dB in "Fast Mode".² "Standard Mode" only.³ mandrel free length > 1.7m⁴ receive test jumper required for <1.7m cable assemblies

Mechanical/Environmental Specifications

Parameter	Specification
Unit Dimensions W x H x D (cm)	
RL1 Automated Return Loss Meter	23.5 x 12 x 32.5 (2U half rack)
RD-S Wireless Remote Head	11 x 8 x 8.5
Shipping Box Dimensions W x H x D (cm)	36.5 x 39 x 53
Unit Weight (kg)	8
Total Shipment Weight (kg)	9
Operating Temperature (°C)	0 to 55
Storage Temperature (°C)	-40 to 70
Humidity (Non-condensing)	Maximum 95% RH from 0 to 40 °C

Optical/Electrical Specifications

Parameter	Specification	
	Single-mode	Multimode
Wavelength Range (nm)	1250 - 1670	840 - 1350
Insertion Loss (dB) ¹	<0.7	
Backreflection (dB) ¹	≤ -60	≤ -40
PDL (dB)	0.05	N/A
Repeatability (dB) ²	± 0.005	
Crosstalk (maximum) (dB)	-80	
Maximum Input Power (dBm)	23	
Switch Life	10 ⁸ cycles	
Switching Time (ms)	300	
Control	USB or Ethernet	
Input Voltage	100 - 240 V AC, 50 - 60 Hz	
Power Consumption (VA)	60 maximum	
Display	Optional 5" touch screen	

Notes:

¹ Excluding connectors.² Sequential switching. Add ±0.02 for random

Mechanical/Environmental Specifications

Parameter	Specification					
	2U half rack		3U full rack		6U full rack	
Max Channel Count	FC	SC	FC	SC	FC	SC
	Without Touchscreen		1x185	1x135	1x400	
	With 5" Touchscreen		1x125	1x95	1x360	
Unit Dimensions W x H x D (cm)	23.5 x 12 x 32.5		44.5 x 13.5 x 45		44.5 x 26.6 x 49.6	
Shipping Box Dimensions W x H x D (cm)	36.5 x 39 x 53		53 x 32 x 57		53 x 45 x 57	
Unit Weight (kg)	8		14		18	
Total Shipment Weight (kg)	9		15		20	
Operating Temperature (°C)	0 to 55					
Storage Temperature (°C)	-40 to 70					
Humidity (Non-condensing)	Maximum 95% RH from 0 to 40°C					