



### Product Description

The RL1 Automated Return Loss Meter has been precisely designed for the most accurate mandrel-free insertion loss and return loss measurements available in the industry. The RL1 is capable of testing even the most challenging fiber optic cable assemblies and components with smart integrated analysis settings adaptable to user requirements.

It is important for the RL1 to be flexible as applications keep changing with new industry requirements. JGR has designed the RL1 to be chassis modular, allowing for quick pairing to equipment in the XN1 family via USB connection. The RL1 can contain up to 4 built-in wavelengths (850, 1300, 1310, 1490, 1550, 1625, 1650nm) with the option of a dual front panel output.

The RL1 can be paired with up to 16 RD-S Wireless Remote-head Detectors. The re-designed integrating sphere can measure loss on dense 72 channel MTP/MPO and also duplex LC with one connection. The RD-S comes standard with SD Slide Detector adapters allowing for the ultimate in ease-of-use.

Unique to the RL1, the optical meter has been designed with many innovative smart features that increase production efficiency and improve overall usage.

### KEY FEATURES

- Most accurate RL in its class
- Self-calibration
- Chassis modular
- Wireless integrating sphere detector
- No computer required
- Ready for production automation
- Barcode control available
- XN1 ready

### APPLICATIONS

- Testing of IL/RL of fiber optic assemblies
- Single and multi-fiber testing
- SM 1310nm, 1490nm, 1550nm, 1625nm
- MM 850nm, 1300nm
- QA and R&D testing

### COMPLIANCE

- Multimode meets IEC 61280-4-1 Encircled Flux standard

### IN THE BOX

- RL1
  - USB A-USB B (1.5m)
  - Ethernet cable (1.5m)
  - SD00 detector cap
  - SD01 FC detector adapter
  - FC/APC-FC/APC jumper (3m)
  - FC/APC-FC/UPC jumper (3m)
- RD-S
  - M12 cable (1.5m)
  - SD00 detector cap
- SX1
  - AC power cord
  - Test report

### Optimized for Speed and Accuracy

The user can choose between "Fast" and "Standard" modes. Fast mode measures IL/RL in less than 1.5 seconds per wavelength with the same accuracy as other premium test solutions up to 75 dB. Standard mode's accuracy surpasses all other commercially available cable assembly test solutions and can accurately measure RL up to 85 dB.



### Self-calibration

The RL1 Automated Return Loss Meter does not need to be sent back to JGR for annual calibration. The self-calibration feature provides step-by-step instructions and generates a calibration report thereby minimizing production down-time and assuring measurement reliability.

### Wireless Remote-head Detector

The RD-S Wireless Remote-head Detector is an optional feature of the RL1 which helps optimize expensive facility desk space. It can be wired to the rear panel of the RL1 or operated wirelessly for maximum flexibility.

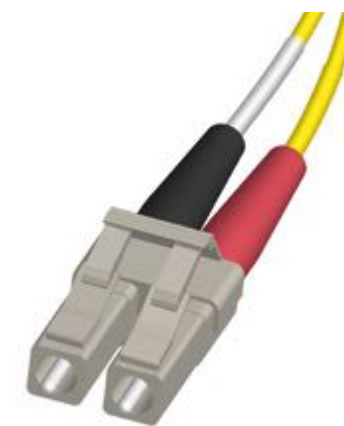

### Duplex Ready

The RL1 is available with dual outputs allowing for faster duplex assembly testing without the need of an additional switch. The new integrating sphere in the front panel detector or RD-S remote-head detector can measure IL on a duplex LC connector in one connection for simple automated testing. If duplex polarity is a concern, an additional RD-S remote-head detector can be paired to identify duplex polarity.

**Touchscreen**

The large RL1 touchscreen display allows users to clearly see device under test results through colour coded pass/fail results. With the RL1 touchscreen, operators can load pre-defined custom test plans for automated testing, or they can manually perform specific individual measurements.

Fiber 1 a/b	IL <sub>1</sub> (dB)	RL <sub>a</sub> (dB)	RL <sub>b</sub> (dB)
3.5m			
1310	0.13	65.3	65.3
1490	0.14	65.4	65.4
1550	0.15	64.7	65.5
1625	0.21	63.2	62.2

12\*MTP/APC(m)-12\*MTP/APC(m) SN:123456

**Automated Measurements Made Easy**

The RL1 Automated Return Loss meter has been designed with the future of automated cable assembly testing in mind. Automation is much more obtainable with the new easily interchangeable SD slide detector adapters, RD-S wireless remote-head detectors and the easy to program test plans. The testing stage can now be automated using Ethernet to synchronize automated mechanical movements with remote measurements.



**Chassis Modular**

The RL1 can be connected directly to an additional SX1 switch for multi-fiber testing. The RL1 takes full control of the switch, automating measurements while storing all references and results. If desired, a second SX1 switch can be connected to measure insertion loss, return loss, and verify mapping of multi-fiber connectors or complex assemblies.



**No Computer Required**

The RL1 is self-sufficient and does not require a PC for automated measurements. Manufacturing facilities are often fighting to keep up with the ever changing lifecycles of Windows operating systems or troubleshooting incompatible Linux systems, this is no longer an issue with the RL1. Multiple units can be connected to a local area network to save results to a database. One central server can maintain all test plan information as well as test results for multiple production lines. Test plans can be loaded into the unit using the front panel touchscreen or a barcode reader.

**Scan and Test**

Barcode scanners can be connected directly to the RL1 allowing operators to save results to a central database along with any other data contained in the barcode. Barcodes can also be used to quickly load test plans or provide custom field information. Using a barcode scanner will eliminate the need for manual user input resulting in fewer errors and faster production.



**XN1 Ready**

All RL1's in a facility can communicate directly to the XN1 server which can be installed on any computer or server connected on the same network as the RL1. The XN1 server can manage all test equipment, test plans, test results, labels and allow communication from one piece of JGR test equipment to another. This creates an ecosystem of test equipment and information in one centralized location.



Ordering Scheme & Instructions

1 - Configure RL1 meter

Single-mode version

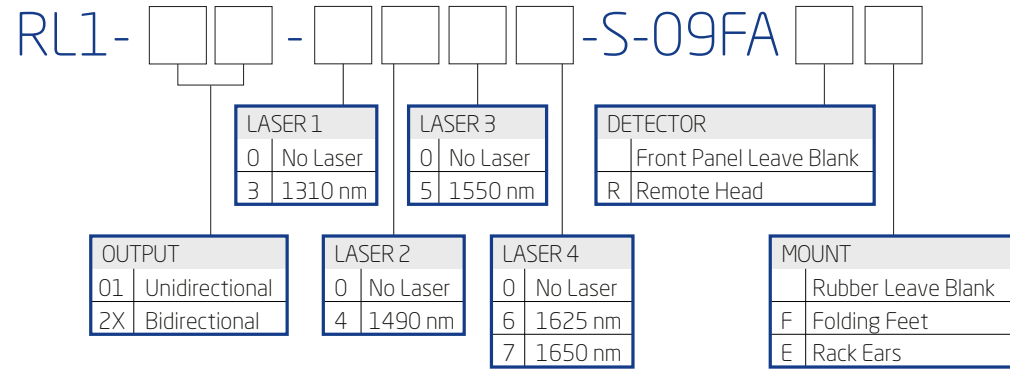

Multimode version

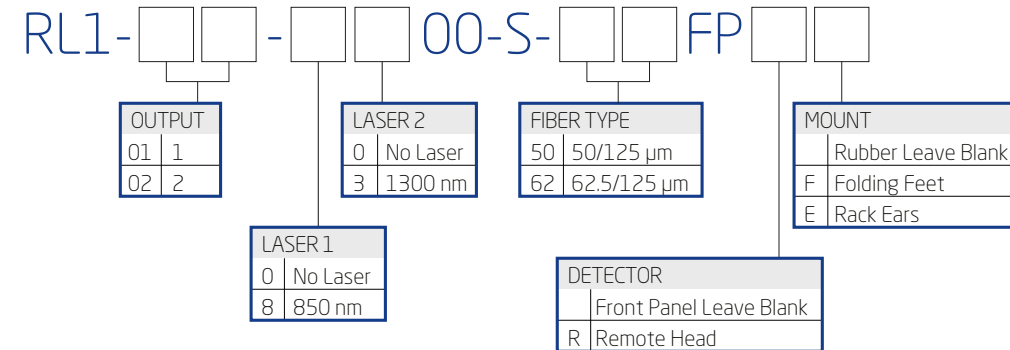

2 - Configure SX1 switch *\*if no switch needed, skip ahead*

Switch chassis

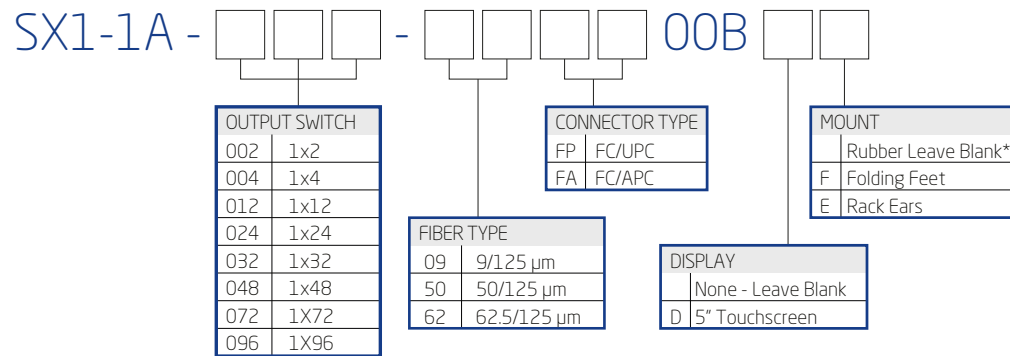

\*Rubber bezel only available in 2U half rack

3 - Add accessories

Additional remote-head detector

RD-S



\*each RL1 can pair with up to 16 remote-head detectors at once

Barcode Scanner

USB-BARCODE



Slide detector adapters



SD [ ] [ ]

TYPE					
00	Cap	14	MU	20	DA113 Barrel
01	FC	15	E2000	21	BFA3000 Barrel
02	ST	16	Universal 2.5.	26	Universal 1.6
03	SC	17	MTP/MPO	34	LC Duplex
04	Universal 1.25.	18	LC	35	Optitap
12	MT	19	MT-RJ	37	MXC
				38	MTPO/MPO-16
				64	CS
				67	SN
				68	MDC

More detector adapters available upon request. See more details on pg 110.

2U Rack Short ear  
2U-RACK-SHORT-EAR



2U Rack Long ear filler plate  
2U-RACK-LONG-EAR



2U chassis connector plate  
2U-CONNECTOR-PLATE



2U rubber bezels  
2U-BEZEL



Flip-out Feet  
CHASSIS-FEET



## Optical/Electrical Specifications

Parameter	Specification	
	Single-mode	Multimode
Fiber Type (µm)	9/125	50/125 and/or 62.5/125
Encircled Flux Standard	N/A	IEC 61280-4-1
Operating Wavelengths (nm)	1310 / 1490 / 1550 / 1625 / 1650	850 / 1300
Return Loss Range (dB)	30 to 85	10 to 60
Return Loss Accuracy (dB)	± 1.0 (30 to 70)	± 1.4 (10 to 30)
	± 1.3 (70 to 75) <sup>1</sup>	± 1.9 (30 to 40)
	± 2.9 (75 to 80) <sup>2</sup>	± 2.2 (40 to 43)
	± 3.9 (80 to 85) <sup>2</sup>	± 4.7 (43 to 60)
Detector Type	Wide Area Integrating Sphere	
Insertion Loss Accuracy (dB)	± 0.03 (<5 dB loss)	
	± 0.15 (≥5 dB loss)	
Testing Time (s)		
Standard Mode	<5 per wavelength	
Fast Mode	<1.5 per wavelength	
Cable Assembly Length (m)		
RL mode	<4000 <sup>3</sup>	
RL <sub>total</sub> mode	<4000 <sup>4</sup>	N/A
Remote Interface	Ethernet / USB	
Display	5" touch screen	
Input Voltage	100 - 240 V AC, 50 - 60 Hz	
Power Consumption (VA)	60 maximum	

Notes:

<sup>1</sup> add ±0.4 dB in "Fast Mode".<sup>2</sup> "Standard Mode" only.<sup>3</sup> mandrel free length > 1.7m<sup>4</sup> receive test jumper required for <1.7m cable assemblies

## Mechanical/Environmental Specifications

Parameter	Specification
Unit Dimensions W x H x D (cm)	
RL1 Automated Return Loss Meter	23.5 x 12 x 32.5 (2U half rack)
RD-S Wireless Remote Head	11 x 8 x 8.5
Shipping Box Dimensions W x H x D (cm)	36.5 x 39 x 53
Unit Weight (kg)	8
Total Shipment Weight (kg)	9
Operating Temperature (°C)	0 to 55
Storage Temperature (°C)	-40 to 70
Humidity (Non-condensing)	Maximum 95% RH from 0 to 40 °C

## Optical/Electrical Specifications

Parameter	Specification	
	Single-mode	Multimode
Wavelength Range (nm)	1250 - 1670	840 - 1350
Insertion Loss (dB) <sup>1</sup>	<0.7	
Backreflection (dB) <sup>1</sup>	≤ -60	≤ -40
PDL (dB)	0.05	N/A
Repeatability (dB) <sup>2</sup>	±0.005	
Crosstalk (maximum) (dB)	< -80	
Maximum Input Power (dBm)	23	
Switch Life	10 <sup>8</sup> cycles	
Switching Time (ms)	300	
Remote Interface	Ethernet / USB	
Input Voltage	100 - 240 V AC, 50 - 60 Hz	
Power Consumption (VA)	60 maximum	
Display	Optional 5" touch screen	

Notes:

<sup>1</sup> Excluding connectors<sup>2</sup> Sequential switching. Add ±0.02 for random

## Mechanical/Environmental Specifications

Parameter	Specification	
	2U half rack	3U full rack
Max Output Channels		
Without Touchscreen	up to 1x36	up to 1x96
With 5" Touchscreen	up to 1x12	up to 1x48
Unit Dimensions W x H x D (cm)	23.5 x 12 x 32.5	44.5 x 13.5 x 45
Shipping Box Dimensions W x H x D (cm)	36.5 x 39 x 53	53 x 32 x 57
Unit Weight (kg)	8	14
Total Shipment Weight (kg)	9	15
Operating Temperature (°C)	0 to 55	
Storage Temperature (°C)	-40 to 70	
Humidity (Non-condensing)	Maximum 95% RH from 0 to 40°C	