

10Gb/s 80Km SFP+ 1550nm Transceivers RTXM228-411



The 1550nm cooled EML laser based 10Gigabit SFP+ Transceiver is designed to transmit and receive serial optical data over single mode optical fiber with 80Km.

They are compliant with SFF-8431,SFF-8432, 10GFC Rev 4.0, and 10GBASE-ZR. The transmitter converts serial CML electrical data into serial optical data compliant with the IEEE 802.3ae standard. The receiver converts serial optical data into serial CML electrical data. Digital diagnostics functions are available via a 2-wire serial interface, as specified in SFF-8472.

Features

- Compliant to SFP+ MSA
- Fully RoHS Compliant
- All metal housing for superior EMI performance
- Operating data rate up to 11.3Gbps
- Cooled EML DFB Laser
- High sensitivity APD photodiode and TIA
- LC duplex connector
- Hot pluggable 20pin connector
- Low power consumption <1.8 W
- -5°C to 70°C operating wide temperature range
- Single +3.3V±5% power supply
- Digital Monitoring SFF-8472 Rev 10.2 compliant
- Real time monitoring of:
Transmitted optical power
Received optical power
Laser bias current

Specifications

(Tc=-5 °C to 70 °C and Vcc= 3.14 to 3.46V)

Parameter	Symbol	Unit	Min	Typ	Max	Note
Transmitter						
Nominal Wavelength	λ	nm	1530		1565	
Side Mode Suppression Ratio	SMSR	dB	30			
Spectral Width(-20dB)	$\Delta\lambda$	nm			0.3	
Optical Output Power	Pav	dBm	0		4	
Extinction Ratio	ER	dB	8.2			
Average Launch Power of OFF Transmitter	POFF	dBm			-30	
Relative Intensity Noise	RIN	dB/Hz			-128	
Receiver						
Center Wavelength	λ_C	nm	1260		1620	
Receiver Sensitivity@10.3125Gb/s	RSENSE	dBm			-24	1
Receiver Sensitivity at 1600ps/nm @ 10.3125Gb/s	RSENSE	dBm			-22	1.2
Overload		dBm	-7			
Optical Return Loss		dB	27		-	
LOS Assert	LOSA	dBm	-36			
LOS De-Assert LOS	LOSD	dBm			-27	
LOS Hysteresis		dB	0.5		6	

Applications

- 10GBASE-ZR
- 10G Fiber Channel

Note 1: Measured at 1528-1600nm,ER>8.2dBm, PRBS 2³¹-1 and BER better than or equal to 10E-12;

2: loopback using 80km fiber (SMF-28).

10Gb/s 80Km SFP+ 1550nm Transceivers RTXM228-411

Ordering Information

Part No.	Specifications								Application
	Package	Laser	Optical Power	Detector	Sensitivity	Temp	Reach	Other	
RTXM228-411	SFP+	1550nm EML	0~+4dBm	APD	< -24dBm	-5~70°C	80km	DDM	10GBASE-ZR/ZW 10G Fiber Channel

Block diagram

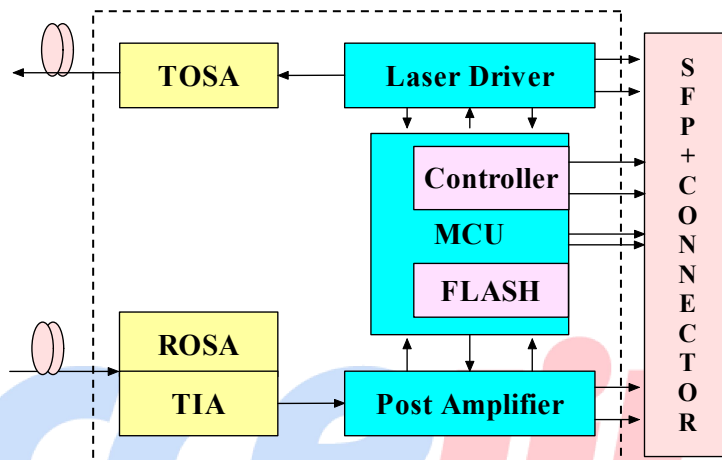

Figure 1. Transceiver functional diagram

Absolute Maximum Ratings

Parameter	Symbol	Unit	Min	Max
Storage Temperature Range	Ts	°C	-40	85
Relative Humidity	RH	%	0	95

Recommended Operating Conditions

Parameter	Symbol	Unit	Min	Typ	Max
Operating Case Temperature Range	Tc	°C	-5		70
Power Supply Voltage	Vcc	V	3.14	3.3	3.46
Bit Rate	BR	Gb/s			11.3
Bit Error Ratio	BER				10 ⁻¹²
Max Supported Link Length	L	Km			80

10Gb/s 80Km SFP+ 1550nm Transceivers RTXM228-411

Electric Ports Definition

Parameter	Symbol	Unit	Min	Typ	Max	Note
Supply Voltage	V_{CC}	V	3.14	3.3	3.46	
Power consumption	Por	W			1.8	
Transmitter						
Input Differential Impedance	R_{IN}	Ω	80	100	120	
Differential Data Input	V_{IN}	mVp-p	180		700	
Transmit Disable Voltage	V_{DIS}	V	2		V_{CCHOST}	
Transmit Enable Voltage	V_{EN}	V	V_{EE}		$V_{EE}+0.8$	
Transmit Fault Assert Voltage	V_{FA}	V	2		V_{CCHOST}	
Transmit Fault De-Assert Voltage	V_{FDA}	V	V_{EE}		$V_{EE}+0.4$	
Receiver						
Differential Data Output	V_{OD}	mVp-p	300		850	
Output Rise Time	t_{RISE}	pS	25			
Output Fall Time	t_{FALL}	pS	25			
LOS Fault	V_{LOSFT}	V	2		V_{CCHOST}	
LOS Normal	V_{LOSNR}	V	V_{EE}		$V_{EE}+0.4$	



Pin function definitions

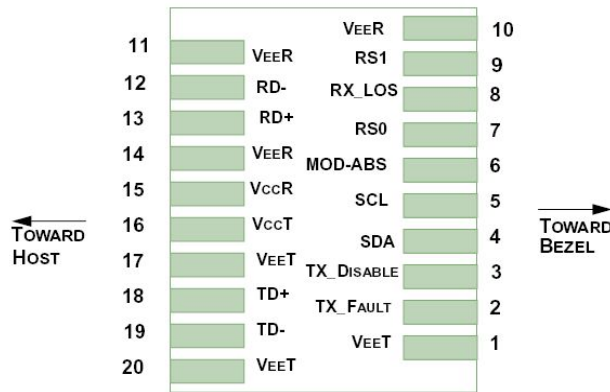

Figure 2. Pin function definitions

Table 1: Transceiver pin descriptions

Pin Number	Symbol	Name	Description
1,17,20	VeeT	Transmitter Signal Ground	These pins should be connected to signal ground on the host board.
2	TX Fault	Transmitter Fault Out (OC)	Logic “1” Output = Laser Fault (Laser off before t_fault) Logic “0” Output = Normal Operation

10Gb/s 80Km SFP+ 1550nm Transceivers

RTXM228-411

			This pin is open collector compatible, and should be pulled up to Host Vcc with a 10kΩ resistor.
3	TX Disable	Transmitter Disable In (LVTTL)	Logic "1" Input (or no connection) = Laser off Logic "0" Input = Laser on This pin is internally pulled up to VccT with a 10 kΩ resistor.
4	SDA		Serial ID with SFF 8472 Diagnostics
5	SCL	Module Definition Identifiers	Module Definition pins should be pulled up to Host Vcc with 10 kΩ resistors.
6	MOD-ABS		
7	RS0	Receiver Rate Select (LVTTL)	These pins have an internal 30kΩ pull-down to ground. A signal on either of these pins will not affect module performance.
9	RS1	Transmitter Rate Select (LVTTL)	
8	LOS	Loss of Signal Out (OC)	Sufficient optical signal for potential BER < 1x10 ⁻¹² = Logic "0" Insufficient optical signal for potential BER < 1x10 ⁻¹² = Logic "1" This pin is open collector compatible, and should be pulled up to Host Vcc with a 10kΩ resistor.
10,11,14	VeeR	Receiver Signal Ground	These pins should be connected to signal ground on the host board.
12	RD-	Receiver Negative DATA Out (CML)	Light on = Logic "0" Output Receiver DATA output is internally AC coupled and series terminated with a 50Ω resistor.
13	RD+	Receiver Positive DATA Out (CML)	Light on = Logic "1" Output Receiver DATA output is internally AC coupled and series terminated with a 50Ω resistor.
15	VccR	Receiver Power Supply	This pin should be connected to a filtered +3.3V power supply on the host board. See Figure 3.Recommended power supply filter
16	VccT	Transmitter Power Supply	This pin should be connected to a filtered +3.3V power supply on the host board. See Figure 3.Recommended power supply filter
18	TD+	Transmitter Positive DATA In (CML)	Logic "1" Input = Light on Transmitter DATA inputs are internally AC coupled and terminated with a differential 100Ω resistor.
19	TD-	Transmitter Negative DATA In (CML)	Logic "0" Input = Light on Transmitter DATA inputs are internally AC coupled and terminated with a differential 100Ω resistor.

10Gb/s 80Km SFP+ 1550nm Transceivers RTXM228-411

Typical Application Circuit

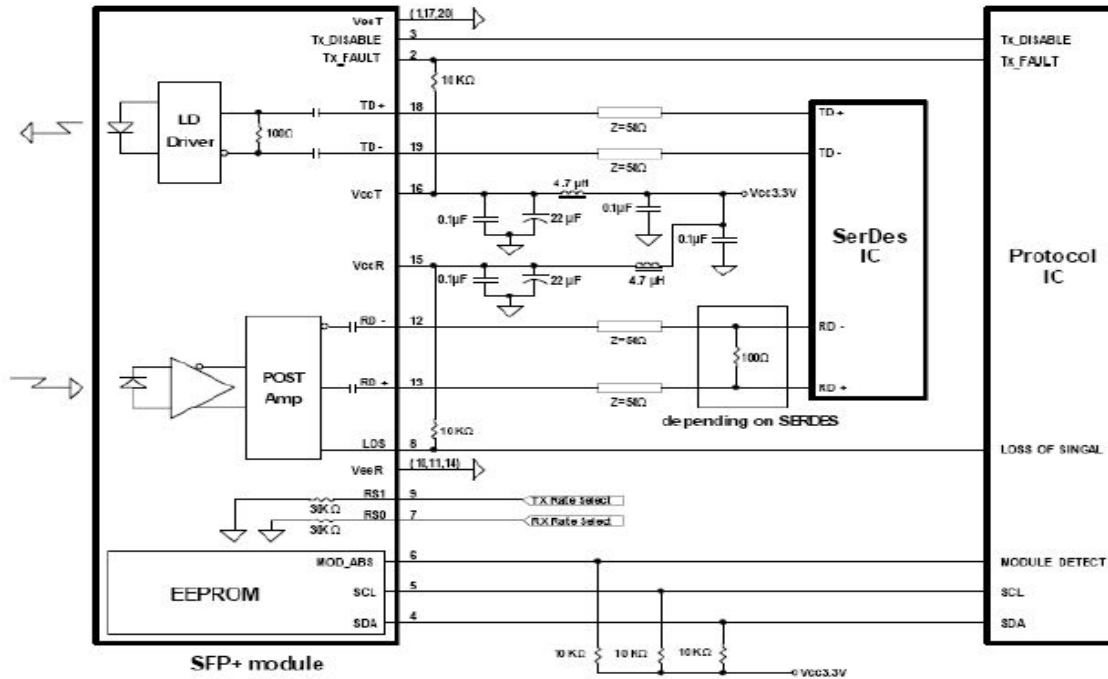

Package Outline

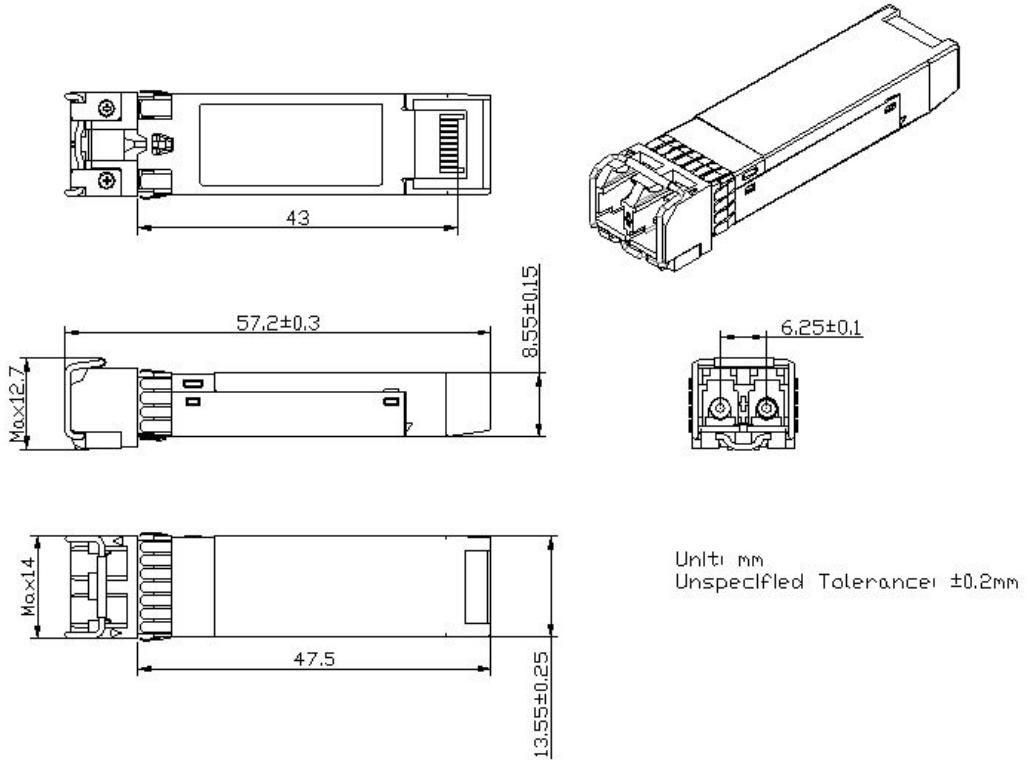

10Gb/s 80Km SFP+ 1550nm Transceivers RTXM228-411

Regulatory Compliance

Feature	Test Method	Performance
Electrostatic Discharge (ESD) to the Electrical Pins	MIL-STD-883C Method 3015.7	Class 1 (> 1500 Volts)
Electrostatic Discharge (ESD) to the Duplex LC Receptacle	Variation of IEC 61000-4-2	Typically, no damage occurs with 15 kV when the duplex LC connector receptacle is contacted by a Human Body Model probe.
Electrostatic Interference (EMI)	CISPR22 ITE Class B EN55022 Class B FCC Class B	Compliant with standards
Immunity	IEC61000-4-3 Class 2 EN55024	Typically show no measurable effect from a 3V/m field swept from 80 to 1000MHz applied to the transceiver without a chassis enclosure.
RoHS Compliance		Less than 1000 ppm of cadmium, lead, mercury, hexavalent chromium, polybrominated biphenyls, and polybrominated biphenyl ethers.



The logo for Accelink, featuring the word "Accelink" in a stylized font. "Accel" is in blue and "ink" is in red. The dot on the "i" is a red circle.