

NG-PON2 ONU Optical Transceiver XFP Module

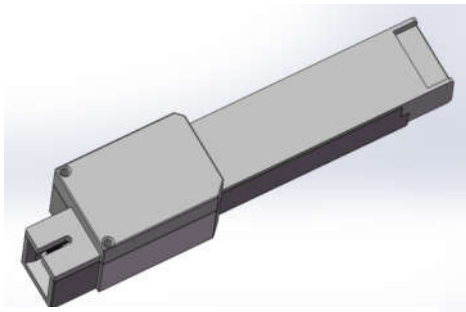

The NG-PON2 ONU Transceiver is designed for NG-PON2 transmission. The module incorporates 9.95328Gb/s C-band burst-mode transmitter and 9.95328Gb/s L-band continuous-mode receiver. An integrated WDM coupler can separate C-band input light and L-band output light. The metallic package guarantees excellent EMI and EMC characteristics, which totally comply with international relevant standards.

Features

- Integrated Single fiber bi-directional optical subassembly
- Symmetric 9.95328Gb/s upstream and downstream bit rate
- XFP metallic package, SC/UPC connector
- +3.3V single power supply
- Low power consumption
- 0 to 70°C operating case temperature
- Burst enable :L-active
- Class 1 Laser eye safety
- Excellent EMI and EMC characteristics
- Compliant with RoHS&WEEE

Applications

- Symmetric 10-Gigabit capable passive optical network(NG-PON2) system

Standards

- MSA SFF-8077iv4.5
- ITU-T G.989.2 N1 class

Specifications

(tested under recommended operating conditions, unless otherwise noted)

Parameter	Symbol	Unit	Value			Note
			Min	typical	Max	
Electrical Characteristics						
Power Consumption		W	-	-	3.5	
LVPECL Single Ended Data Input Swing		mV	100	-	800	
CML Single Ended Data Output Swing		mV	200		600	
Differential Data input impedance		Ω	-	100	-	
Signal Level(LVTTL)	VOH	V	2.4	-	V _{cc}	
	VOL	V	0	-	0.8	
Optical transmitter Characteristics						
Data Rate		Mbps	--	9953.28	-	
Wavelength Band Range 4	λ _c	nm	1532.68	-	1535.04	
Center Frequency 4	ν _c	Thz	195.6	-	195.3	
Maximum Spectral Excursion (switching duty cycle from5%-95%)		Ghz			±20	
Tuning Range		Ghz			400	
Tuning Time (Channel to Channel)		msec			3000	
Launch Optical Power	P _o	dBm	2	-	7	
Off level light		dBm			-45	
Burst turn on/off time (including wavelength stabling to the MSE mask)	Ton/Toff	ns	-	-	500	
Extinction Ratio 1	EX	dB	6.0		-	
Eye Diagram	Compliant with ITU-T G.989.2					
Transmitter dispersion penalty 2	TDP	dB	-	-	1	
Optical receiver Characteristics						
Data Rate		Mbps	-	9953.28	-	
Center Wavelength Range 4	λ _c	nm	1596.34		1598.89	
Tuning Time (Channel to Channel)		msec			1000	
Receiver Sensitivity 3	S	dBm	-	-29	-28	
Overload Input Optical Power	Pin	dBm	-7			
LOS	Optical Dessert	dB	-	-	-29	
	Optical Assert		-44	-	-	
LOS Hysteresis		dB	0.5	-	6	
Note1. Measured with PRBS 2 ³¹ -1 test pattern @9.95328Gbps. Note2. Transmit on 20km SMF. Note3. Measured with PRBS 2 ³¹ -1 test pattern @9.95328Gbps with Tx on, ER=8.2dB, BER=10 ⁻³ Note4. refer to ITU-T G.989.2 Table VII						

NG-PON2 ONU Optical Transceiver XFP Module

Ordering Information

Part No	Specifications								
	Package	Data rate	Laser	Optical Power	Detector	Sensitivity	Tcase	Reach	Others
RTXM166-801	XFP	9.95328G US 9.95328G DS	C-band tunable LD	2~ 7dBm	L-band tunable APD	-28.0dBm @10e-3	0~70°C	20km	DDM,RoH S

Absolute Maximum Ratings

Parameter	Symbol	Unit	Min	Max
Storage Temperature Range	Ts	°C	-40	+85
Relative Humidity	RH	%	5	95
Power Supply Voltage	Vcc	V	0	+4
Receiver Damage Threshold		dBm	+2	-

Recommended Operating Conditions

Parameter	Symbol	Unit	Min	Typ	Max
Operating Case Temperature Range	Tc	°C	0	-	70
Power Supply Voltage	Vcc	V	3.135	3.3	3.465

Principle diagram

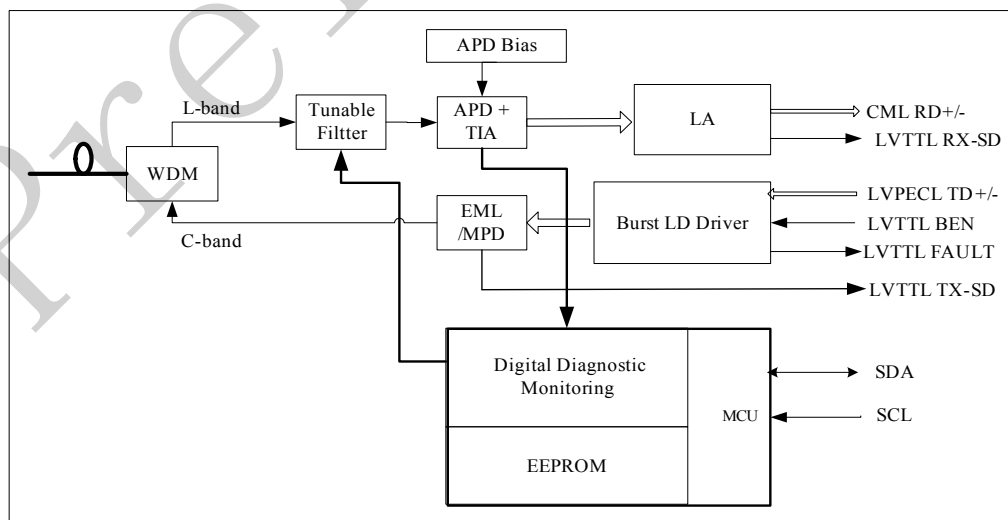

NG-PON2 ONU Optical Transceiver XFP Module

Package Outline(TBD)

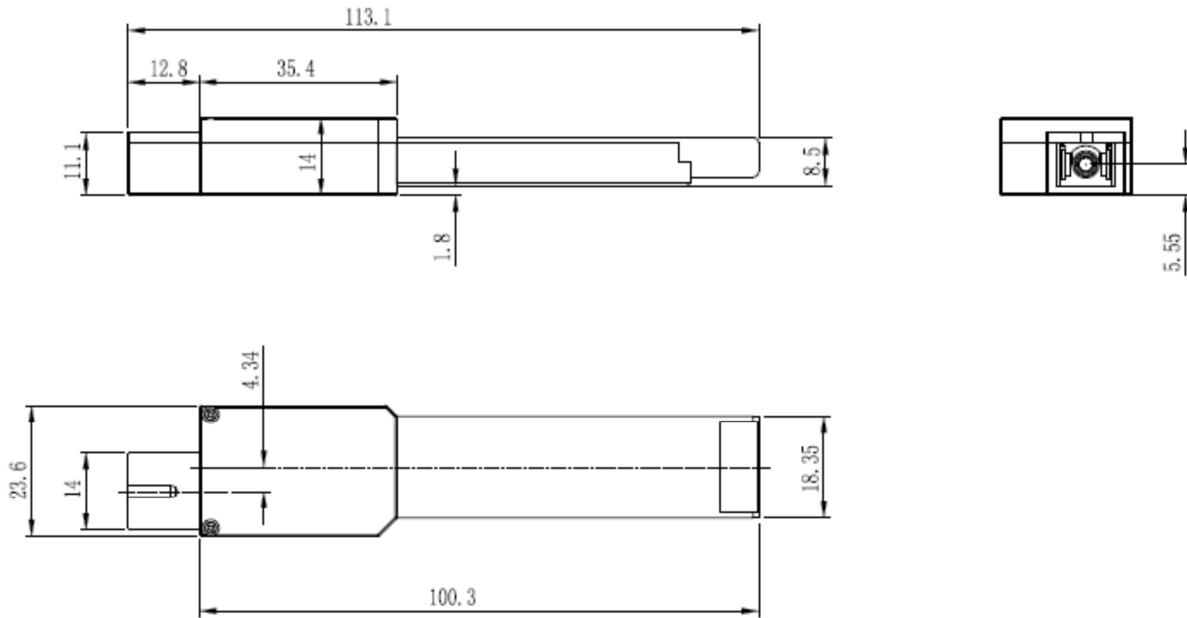

Regulatory Compliance

Feature	Test Method	Performance
Electrostatic Discharge (ESD) to the Electrical Pins	MIL-STD-883E Method 3015.7	Class 1 (>1.5kV) – Human Body Model
Electrostatic Discharge (ESD) Immunity	IEC61000-4-2	LV4(Air discharge 15kV, Contact discharge 8kV) Performance criterion B
Electromagnetic Interference (EMI)	CISPR22 ITE Class B EN55022 Class B	Compliant with standards
Immunity	IEC61000-4-3 Class 2 EN55024	Typically show no measurable effect from a 3V/m field swept from 80 to 1000MHz applied to the transceiver without a chassis enclosure.
Eye Safety	FDA 21 CFR 1040.10 and 1040.11 UL TUV EN 60825-1	Compliant with Class 1 laser product