

Features

- SFP Type LC Dual Receiver
- APD/TIA Receiver
- 3.3V single power supply
- Hot pluggable
- Serial ID information support
- Digital diagnostic
- Compliant with RoHS
- Compliant with UL & TUV



Applications

- 5G Application

Ordering Information

Form Factor	Data Rate	Media	Distance	Wavelength (nm)	RX Sensitivity (dBm)	Voltage (V)	Coupling	DDM (Y/N)	Temperature (°C)	Part Number
SFP-LC	5G	SMF	None	None	< -25	3.3	AC/AC	Y	-20 ~ +93	A5IL0000XDOA0745

Absolute Maximum Ratings

Parameter	Symbol	Conditions	Min	Max	Unit
Storage Temperature	T _S	--	-40	+93	°C
Storage Relative Humidity	RH	--	5	95	%
Supply Voltage	V _{CC}	--	-0.5	3.8	V

Recommended Operating Conditions

Parameter	Symbol	Conditions	Min	Typ	Max	Unit
Operating Temperature (Case)	T _C	--	-20	--	93	°C
Supply Voltage	V _{CC}	--	3.13	3.3	3.47	V
Supply Current	I _{RX}	--	--	--	450	mA
Inrush Current	I _{CC}	--	--	--	I _{CC} +30	mA
Data Rate	DR	--	--	5	--	Gbps

Electrical Characteristics

Parameter	Symbol	Conditions	Min	Typ	Max	Unit
Receiver						
Differential Output Impedance	R _{DI}	--	--	100	--	Ohm
Differential Output Voltage	V _{DI}	AC-Coupled, peak to peak	0.37	--	2.00	V
Rx LOS Output-High	V _{LOSH}		2.00	--	V _{CC} +0.3	V
Rx LOS Output-Low	V _{LOSL}		0.00	--	0.80	V

Optical Characteristics

Parameter	Symbol	Conditions	Min	Typ	Max	Unit
Receiver						
Operating Wavelength	λ	--	1260	--	1620	nm
Receiver Overload	P _{TN} MAX	1	-8	--	--	dBm
Receiver Sensitivity@5Gbps	P _{TN} MIN	1	--	--	-25	dBm
Receiver Sensitivity@2.5Gbps	P _{TN} MIN	2	--	--	-28	dBm
Rx LOS Assert	P _A	--	-45	--	--	dBm
Rx LOS De-Assert	P _D	--	--	--	-28	dBm
Receiver Loss of Signal Hysteresis		--	0.5	--	6	dB

1. Measured with 5G TX, ER=5dB, PRBS²³ -1 NRZ at 10⁻¹² BER
2. Measured with 2.5G TX, ER=8.2dB, PRBS²³ -1 NRZ at 10⁻¹² BER

HALT Vibration requirement

25°C

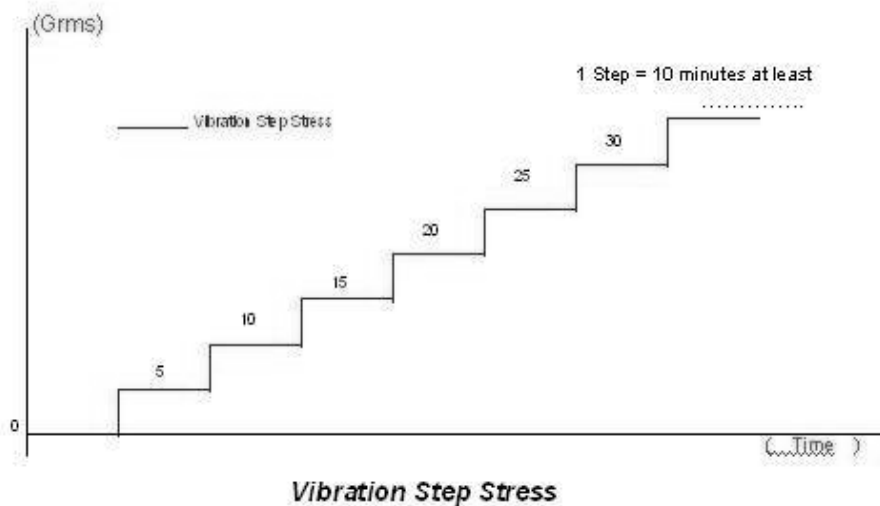

1. Test conducted with samples exercising at maximum data rates.
2. Set start vibration Grms value at 5 G.
3. Each step vibration increased : 5 G.
4. Each step dwell time : 10 minute.
5. Increased Grms value step by step until operation degradation observed to get the operational limit which should be **at least 30G**

Recommended Host Board Supply Filtering Circuit

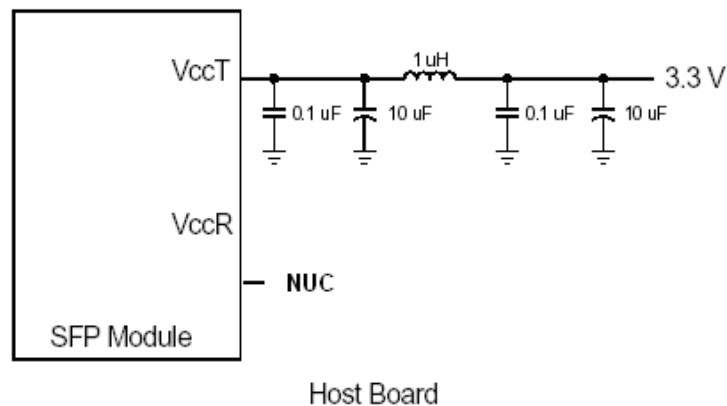

Pin Description

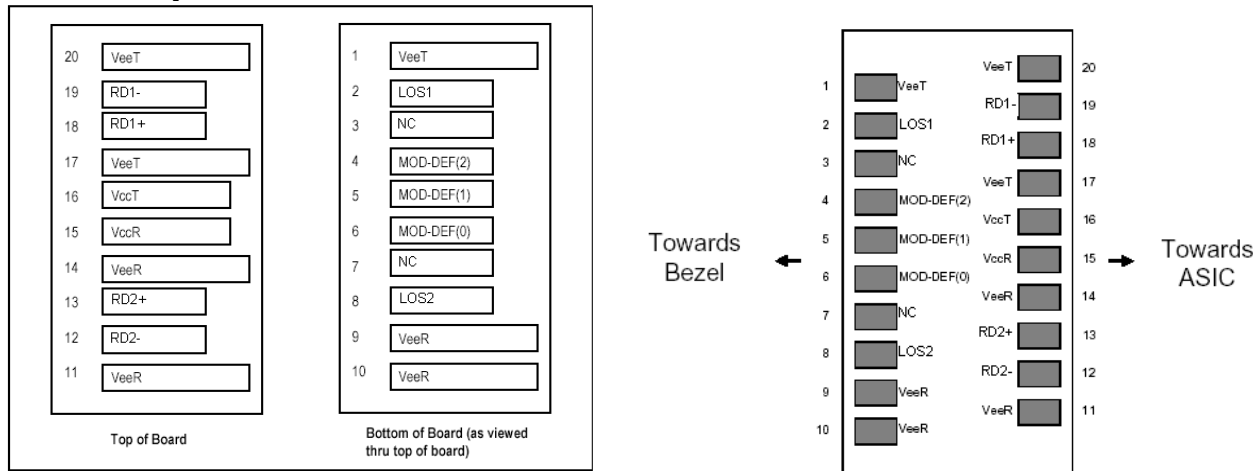

SFP Transceiver Electric Pad Layout

Diagram of Host Board Connector Block Pin Numbers and Names

Pin Function Definitions

Pin No.	Pin Name	Function	Plug Seq.	Note
1	V _{ee} T	Receiver 1 Ground	1	3
2	LOS1	Receiver 1 Loss of Signal	3	4
3	NC	NC	3	
4	MOD_DEF 2	Module Definition 2	3	1
5	MOD_DEF 1	Module Definition 1	3	1
6	MOD_DEF 0	Module Definition 0	3	1
7	NC	NC	3	
8	LOS2	Receiver 2 Loss of Signal	3	4
9	V _{ee} R	Receiver 2 Ground	1	2
10	V _{ee} R	Receiver 2 Ground	1	2
11	V _{ee} R	Receiver 2 Ground	1	2
12	RD2-	Receiver 2 Inv. Data Out	3	5
13	RD2+	Receiver 2 Data Out	3	5
14	V _{ee} R	Receiver 2 Ground	1	2
15	V _{cc} R	Receiver 2 Power	2	3
16	V _{cc} T	Receiver 1 Power	2	3
17	V _{ee} T	Receiver 1 Ground	1	2
18	RD1+	Receiver 1 Data In	3	5
19	RD1-	Receiver 1 Inv. Data In	3	5
20	V _{ee} T	Receiver 1 Ground	1	2

Notes:

Plug Seq.: Pin engagement sequence during hot plugging.

1. Mod-Def 0,1,2. These are the module definition pins. They should be pulled up with a 4.7K - 10K Ω resistor on the host board. The pull-up voltage shall be VccT
Mod-Def 0 is grounded by the module to indicate that the module is present
Mod-Def 1 is the clock line of two wire serial interface for serial ID
Mod-Def 2 is the data line of two wire serial interface for serial ID
2. VeeR and VeeT may be internally connected within the SFP module.
3. VccT, VccR are the Analog, Receiver power supplies. They are defined as 3.3V \pm 5% at the SFP connector pin. Maximum supply current is 450 mA. Recommended host board power supply filtering is shown below. Inductors with DC resistance of less than 1 Ω should be used in order to maintain the required voltage at the SFP input pin with 3.3V supply voltage. When the recommended supply filtering network is used, hot plugging of the SFP module will result in an inrush current of no more than 30 mA greater than the steady state value. VccT, VccR may be internally connected within the SFP module.
4. LOS1, LOS2 (Loss of Signal) is an open collector/drain output, which should be pulled up with a 4.7K -10K Ω resistor on the host board. Pull up voltage between 2.0V and VccT, R+0.3V. When high, this output indicates the received optical power is below the worst-case receiver sensitivity (as defined by the standard in use). Low indicates normal operation. In the low state, the output will be pulled to < 0.8V.
5. RD1-/+, RD2-/+: These are the differential receiver outputs. They are AC coupled 100 Ω differential lines which should be terminated with 100 Ω (differential) at the user SERDES. The AC coupling is done inside the module and is thus not required on the host board. The voltage swing on these lines will be between 600 and 2000 mV differential (185 - 1000 mV single ended) when properly terminated.

Mechanical Design Diagram

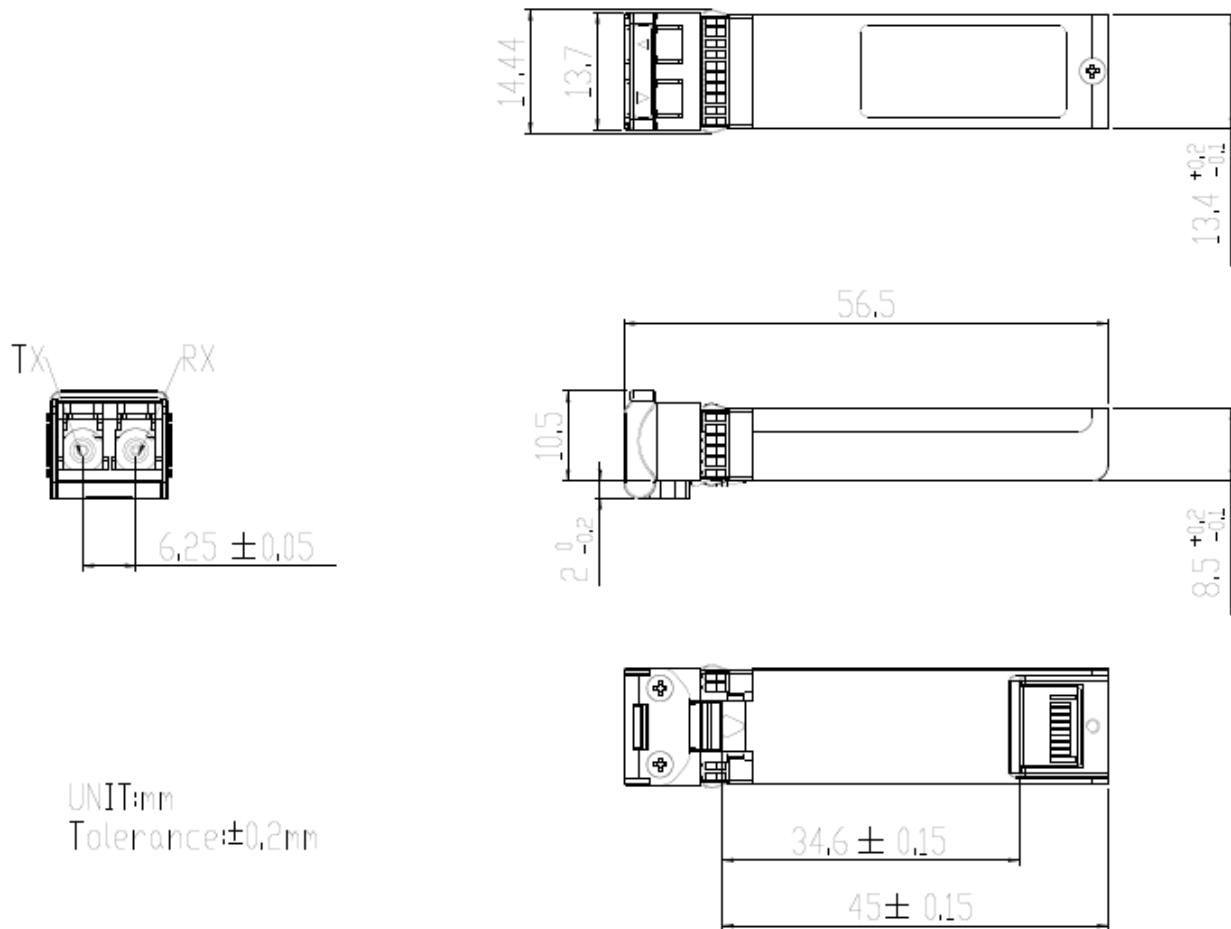

Regulatory Compliance

Item	Standard
Electromagnetic Interference (EMI)	FCC Part 15 Class B EN55022 Class B (CISPR 22B) VCCI Class B
Electrostatic Discharge to the Electrical Pins (ESD)	MIL-STD-883E Method 3015.7
Electrostatic Discharge to the Receptacle (ESD)	IEC 61000-4-2
RoHS	2011/65/EU
Laser Eye Safety	FDA 21CFR 1040.10 and 1040.11
Component Recognition	UL and TUV

Laser Safety Information

All versions of this laser are Class 1 laser products per IEC¹/EN² 60825-1. Users should observe safety precautions such as those recommended by ANSI³ Z136.1-2000, ANSI Z36.2-1997 and IEC 60825-1.

This product conforms to FDA (CDRH) 21 CFR 1040.10 and 1040.11 except for deviations of laser safety class designation pursuant to ['Laser Notice No.50'](#), dated June 24, 2007.

Product labeling:

Class 1 Laser Product
Compliance with 21 CFR
1040.10 and 1040.11

If labeling is not affixed to the module due to size constraints; then rather, labeling is placed on the outside of the shipping box.

This product is not shipped with a power supply.

Caution: use of controls or adjustments or performance of procedures other than those specified herein may result in hazardous radiation exposure.

Certifications

UL	60950-1 (E243407)
TUV	EN60950-1, EN 60825-1, EN 60825-2

Documentation is available upon request.

(1) IEC is a registered trademark of the International Electrotechnical Commission

(2) Within Europe the IEC standard has been adopted as a European Normative standard known as EN 60825, and each European country will have its own version of this standard, for example, the British Standards version known as BS EN 60825. There can be small differences between the different countries versions of EN 60825, and these are in part caused by the process of translating the standard into the native language of that country.

(3) ANSI is a registered trademark of the American National Standards Institute

Note : All information contained in this document is subject to change without notice.