



Applications

- ❑ 10GBASE-LR Ethernet (9.95 to 10.31Gbps)
- ❑ CPRI 7 (9830.4 Mibit/s)

Features

- ❑ SFP+ Type Dual LC Transceiver
- ❑ 1310nm FP Laser
- ❑ PIN Photo Detector
- ❑ 1.4Km transmission with SMF
- ❑ 3.3V single power supply
- ❑ Compliant with SFP+ MSA
- ❑ Compliant with IEEE 802.3ae
- ❑ Hot pluggable
- ❑ Serial ID information support
- ❑ Digital diagnostic SFF-8472 compliant
- ❑ Compliant with RoHS
- ❑ Compliant with UL & TUV
- ❑ Compliant with SFF-8431

Ordering Information

Form Factor	Date Rate	Media	Distance	Wavelength (nm)	TX Power (dBm)	RX Sensitivity (dBm)	Voltage (V)	Coupling	Signal Detect	DDM (Y/N)	Temperature (°C)	Part Number
SFP+LR Lite	10G	SMF	1.4Km	1310	-8.2 ~ 0.5	< -14.4	3.3	AC/AC	TTL	Y	-40 ~ +85	A7ELBN13ADGA0682



Absolute Maximum Ratings

Parameter	Symbol	Conditions	Min	Max	Unit
Storage Temperature	T _S	--	-40	85	°C
Storage Relative Humidity	RH	--	5	95	%
Supply Voltage	V _{CC}	--	0	4.0	V

Recommended Operating Conditions

Parameter	Symbol	Conditions	Min	Typ	Max	Unit
Operating Temperature (Case)	T _C	--	-40	--	85	°C
Supply Voltage	V _{CC}	--	3.14	3.3	3.46	V
Supply Current	I _{TX} + I _{RX}	--	--	--	230	mA
Data Rate	DR	--	9.95	10.31	--	Gbps

Electrical Characteristics

Parameter	Symbol	Conditions	Min	Typ	Max	Unit
Transmitter						
Differential Input Impedance	R _{DI}	--	--	100	--	Ohm
Differential Input Voltage	V _{DI}	AC-Coupled, peak to peak	150	--	1200	mV
Tx Disable Input-High	V _{DISH}	--	2.0	--	V _{CC} +0.3	V
Tx Disable Input-Low	V _{DISL}	--	0	--	0.8	V
Tx Fault Output-High	V _{FOH}	--	2.0	--	V _{CC} +0.3	V
Tx Fault Output-Low	V _{FOL}	--	0	--	0.8	V
Receiver						
Differential Output Impedance	R _{DO}	--	--	100	--	Ohm
Differential Output Voltage	V _{DO}	AC-Coupled, peak to peak	300	--	850	mV
Rx LOS Output-High	V _{LOSH}	--	2.00	--	V _{CC} +0.3	V
Rx LOS Output-Low	V _{LOSL}	--	0.00	--	0.80	V

Optical Characteristics

(V_{CC}=3.14V to 3.46V, 9/125um SMF)

Parameter	Symbol	Conditions	Min	Typ	Max	Unit
Transmitter						
Optical Center Wavelength	λ _c	--	1260	1310	1355	nm
Spectral Width		(-20)	--	--	3	nm
Optical Output Power	P _o	(Avg.)	-8.2	--	0.5	dBm
Optical Extinction Ratio	ER	--	3.5	--	--	dB
Optical Modulation Amplitude	OMA	--	-5.2	--	--	dBm
Relative Intensity Noise	RIN ₁₂ OMA	--	--	--	-128	dB/Hz
Eye Mask			Compliant with IEEE 802.3ae			
Receiver						
Operating Wavelength	λ	--	1260	1310	1620	nm
Receiver Overload	P _{IN} MAX	1	0.5	--	--	dBm
Rx Sensitivity (Avg.) @10.31Gbps	P _{IN} MIN	1	--	--	-14.4	dBm
Rx Sensitivity (OMA) @10.31Gbps	P _{IN} MIN	1	--	--	-12.6	dBm
Rx LOS Assert	LOS _A	--	-30	--	--	dBm
Rx LOS De-Assert	LOS _D	--	--	--	-17	dBm
Rx LOS Hysteresis		--	0.5	--	--	dB
Receiver Reflectance		--	--	--	-12	dB

1. Measured with PRBS 2³¹ -1 at 10⁻¹² BER



Pin Description

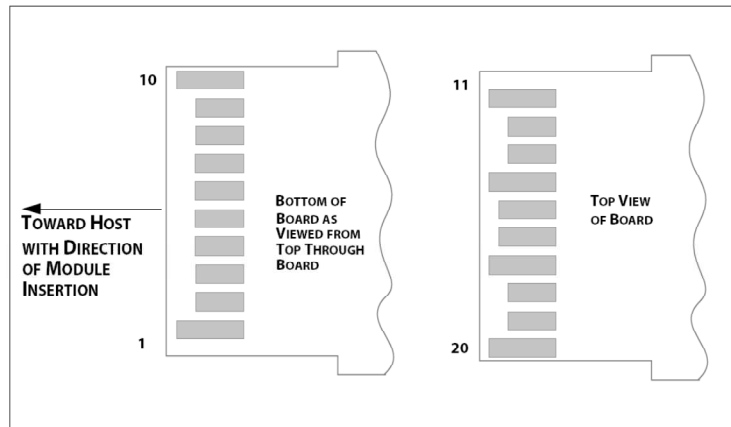

SFP+ Transceiver Electric Pad Layout

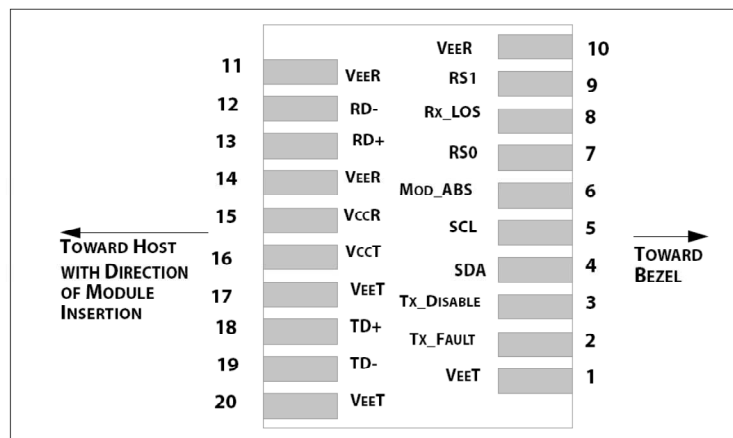

SFP+ Transceiver Host PCB PAD Assignment



Pin Function Definitions

Pin No.	Pin Name	Function/Description	Power Sequence Order	Note
1	VeeT	Transmitter Ground	1st	1
2	Tx_Fault	Transmitter Fault	3rd	2
3	Tx_Disable	Transmitter Disable; Turns off transmitter laser output	3rd	3
4	SDA	2-wire Serial Interface Data Line (MOD-DEF2)	3rd	
5	SCL	2-wire Serial Interface Clock (MOD-DEF1)	3rd	
6	Mod_ABS	Module Absent, connected to VeeT or VeeR in the module	3rd	4
7	RS0	Rate Select 0, (not functional)	3rd	
8	Rx_LOS	Receiver Loss of Signal Indication	3rd	2
9	RS1	Rate Select 1, (not functional)	3rd	
10	VeeR	Receiver Ground	1st	1
11	VeeR	Receiver Ground	1st	1
12	RD-	Receiver Inverted Data Output	3rd	
13	RD+	Receiver Non-Inverted Data Output	3rd	
14	VeeR	Module Receiver Ground	1st	1
15	VccR	Receiver 3.3 V Supply	2nd	
16	VccT	Transmitter 3.3 V Supply	2nd	
17	VeeT	Transmitter Ground	1st	1
18	TD+	Transmitter Non-Inverted Data Input	3rd	
19	TD-	Transmitter Inverted Data Input	3rd	
20	VeeT	Transmitter Ground	1st	1

Notes:

1. The module signal ground contacts, VeeR and VeeT, should be isolated from the module case.
2. This contact is an open collector/drain output contact and shall be pulled up with a 4.7k to 10k Ohms resistor to host_Vcc on the host board. Pull ups can be connected to one of several power supplies, however the host board design shall ensure that no module contact has voltage exceeding module VccT/R + 0.5 V.
3. This contact is an input contact with a 4.7 kΩ to 10k Ohms pull up to VccT inside the module.
4. This contact shall be pulled up with a 4.7k to 10k Ohms resistor to host_Vcc on the host board.



Recommended Interface Circuit

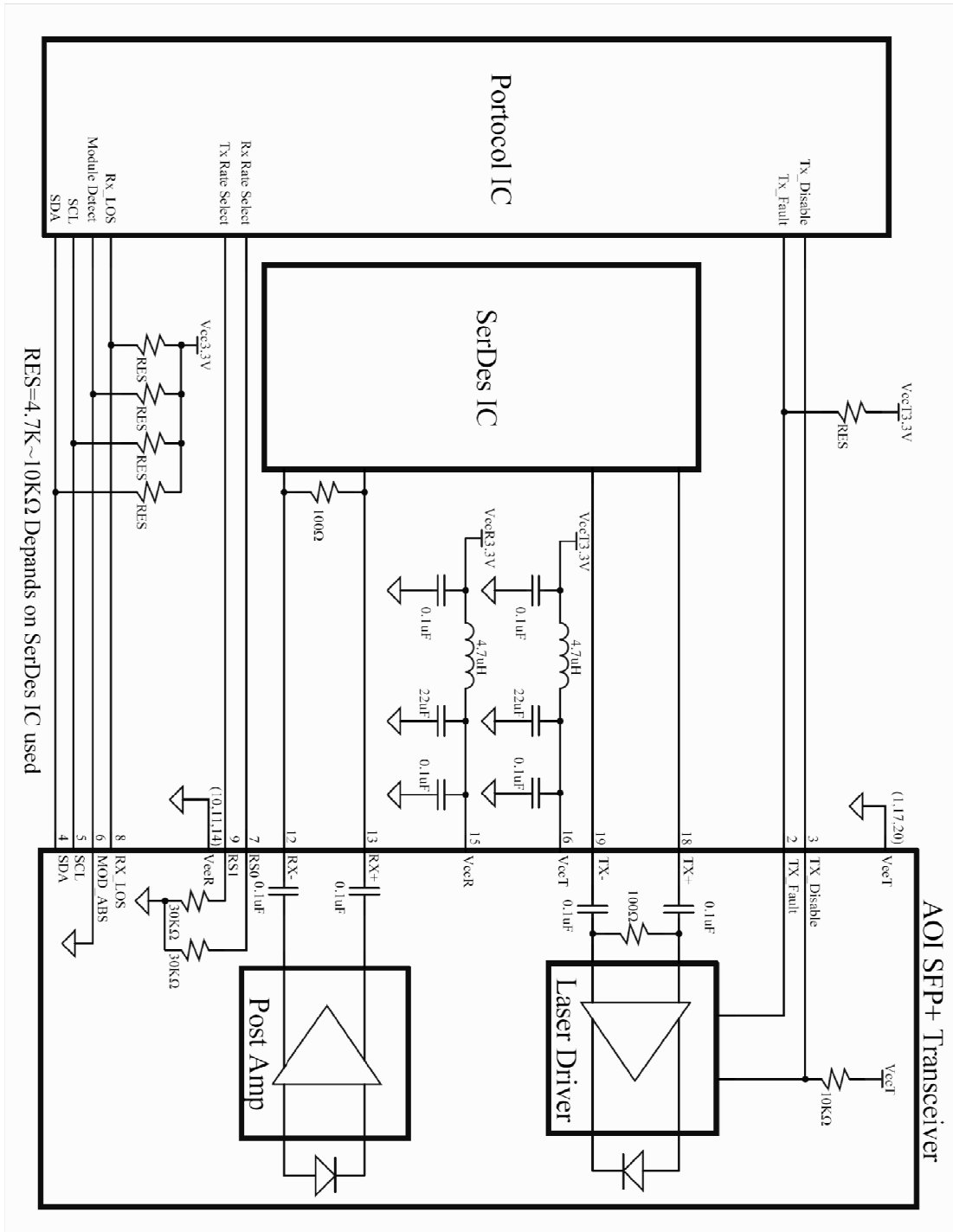



Mechanical Design Diagram

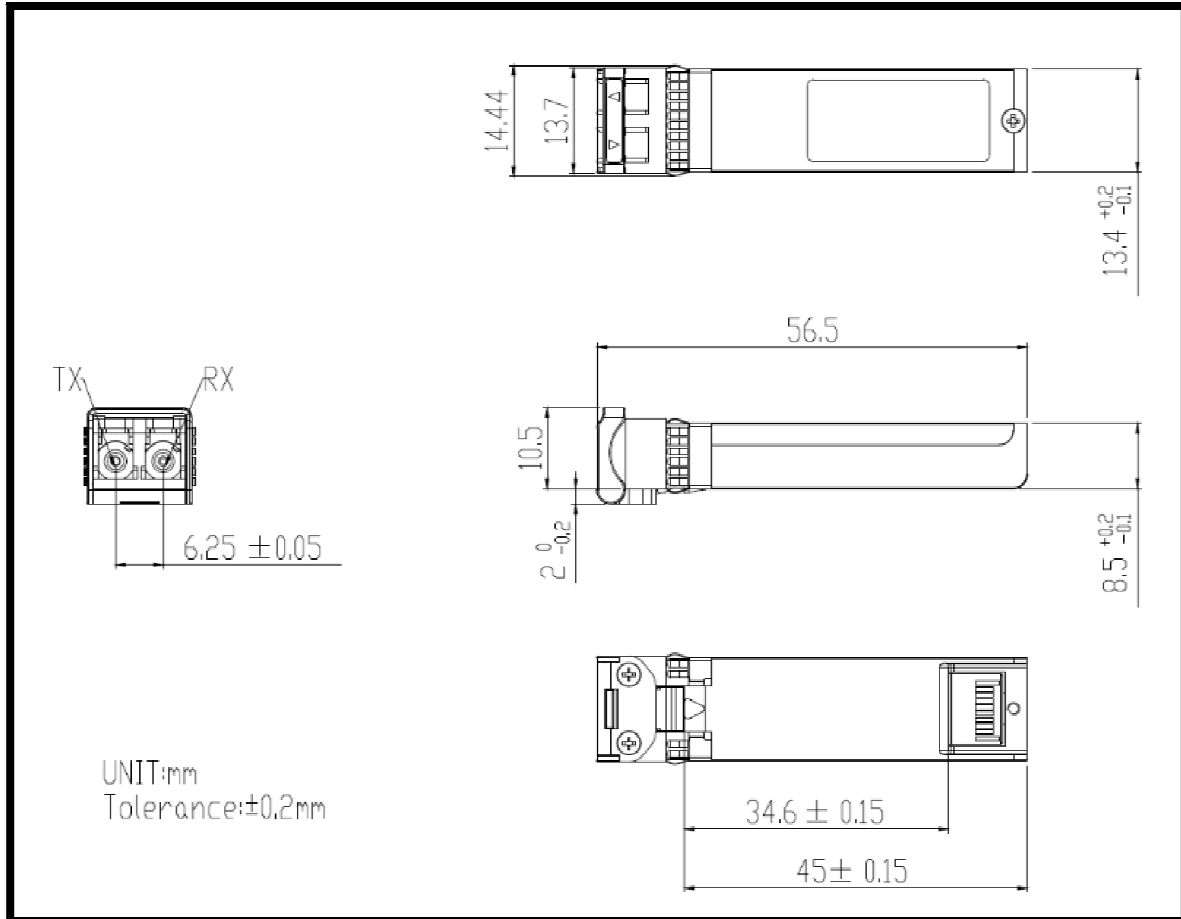



Specific EEPROM Memory Contents Page A0h

	AOI	A7ELBN13ADGA0682	E130	31
Add	Name of field		ASCII	HEX
0	Identifier	03:SFP Transceiver		03
1	Ext. Identifier	04:SFP Transceiver		04
2	Connector	07:LC		07
3	Transceiver	10G Ethernet 20:10G Base-LR		20
4		SONET/SDH		00
5		SONET/SDH		00
6		Ethernet		00
7		Fiber Channel		00
8		Fiber Channel		00
9		Fiber Channel		00
10		Fiber Channel		00
11	Encoding	01:8B10B, 03:NRZ, 05:SONET, 06:64B/66B,		06
12	BR, Nominal	100Mbps/unit -> HEX 67:10.3125G		67
13	Reserved	Reserved		00
14	Length(9um, km)	1km /unit -> HEX 01:1KM		01
15	Length (9um)	100m /unit -> HEX 0E:1400M		0E
16	Length (50um), OM2	10m /unit -> HEX		00
17	Length (62.5um), OM1	10m /unit -> HEX		00
18	Length (Copper)	1m /unit -> HEX		00
19	Length (50 um), OM3	10m /unit -> HEX		00
20	Vendor name	SFP Vendor Name (ASCII)	A	41
21			O	4F
22			I	49
23				20
24				20
25				20
26				20
27				20
28				20
29				20
30				20
31				20
32				20
33				20
34				20



SFP+ LR Lite 10G SMF 1.4Km 1310nm I-temp Transceiver

A7ELBN13ADGA0682

35				20
36	Reserved	Reserved		00
37				00
38	Vendor OUI	SFP Vendor IEEE company ID, No ID set "00"		00
39				00
40	Vendor PN	SFP Vendor Part Number (ASCII)	A	41
41			7	37
42			E	45
43			L	4C
44			B	42
45			N	4E
46			1	31
47			3	33
48			A	41
49			D	44
50			G	47
51			A	41
52			0	30
53			6	36
54	8	38		
55	2	32		
56	Vendor rev	Hardware Revision (HEX) Ver B	B	42
57			0	30
58		Firmware Revision (HEX) V3.00	3	33
59	0		30	
60	Wavelength	Wavelength -> HEX (051E: 1310nm)		05
61				1E
62	Reserved			00
63	CC_BASE	Check Sum 0 to 62 byte		F5
64				00
65	Options	18:TX-DIS,TX_Fault 1A:TX-DIS,TX_Fault,RX-LOS		1A
66	BR, max	1% /unit		00
67	BR, min	1% /unit		00
68	Vendor SN	Vendor SN (ASCII)		XX
69				XX
70				XX
71				XX
72				XX
73				XX
74				XX



SFP+ LR Lite 10G SMF 1.4Km 1310nm I-temp Transceiver

A7ELBN13ADGA0682

75				XX
76				XX
77				XX
78				XX
79				XX
80				XX
81				XX
82				XX
83				XX
84	Date code	Year (ASCII)		XX
85				XX
86		Month (ASCII)		XX
87				XX
88		Day (ASCII)		XX
89				XX
90		Blank		20
91				20
92	Diagnostic Monitoring Type	58:W/I DDM(Ext_Cal), 68:W/I DDM(Int_Cal)		68
93	Enhanced Options	E0:A/W, Tx_Dis, Tx_fault F0:A/W, Tx_Dis, Tx_fault, Rx_LOS B0:A/W, Tx_fault, Rx_LOS		F0
94	SFF-8472 Compliance	01:9.3, 02:9.5, 03:10.2, 04:10.4, 05:11.0		05
95	CC_EXT	Check Sum 64 to 94 byte		XX
96-127	Read-only	Read-only		00



Product Label

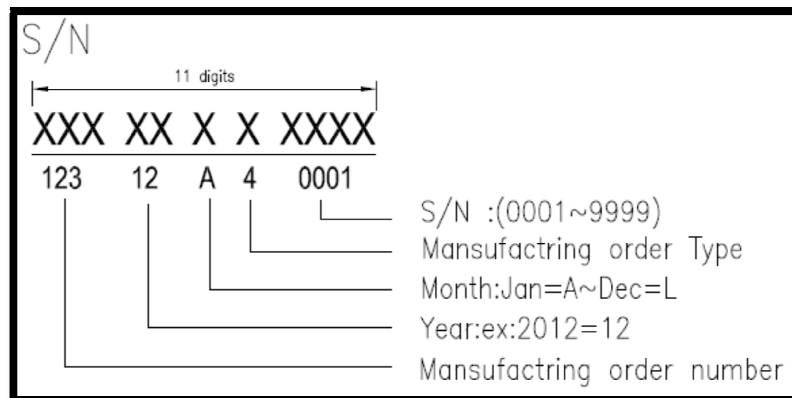
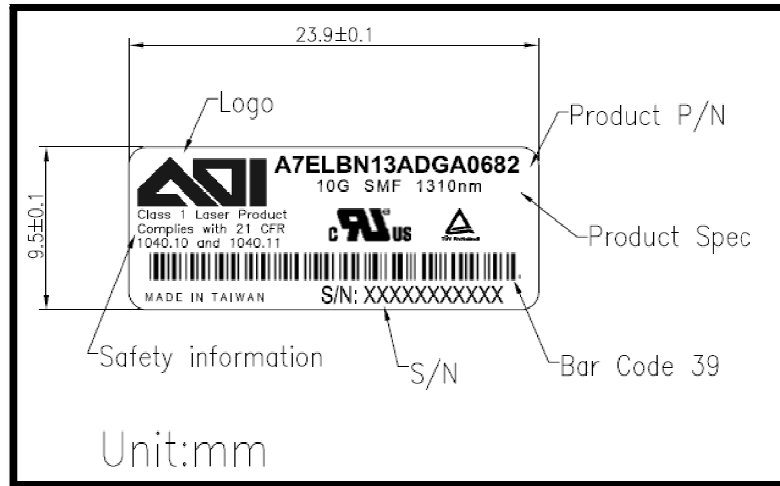



Regulatory Compliance

Item	Standard
Electromagnetic Interference (EMI)	FCC Part 15 Class B EN55022 Class B (CISPR 22B) VCCI Class B
Electrostatic Discharge to the Electrical Pins (ESD)	MIL-STD-883E Method 3015.7
Electrostatic Discharge to the Receptacle (ESD)	IEC 61000-4-2
RoHS	2011/65/EU
Laser Eye Safety	FDA 21CFR 1040.10 and 1040.11
Component Recognition	UL and TUV

Laser Safety Information

All versions of this laser are Class 1 laser products per IEC¹/EN² 60825-1. Users should observe safety precautions such as those recommended by ANSI³ Z136.1, ANSI Z36.2 and IEC 60825-1.

This product conforms to FDA (CDRH) 21 CFR 1040.10 and 1040.11 except for deviations of laser safety class designation pursuant to Laser Notice No.50¹.

Product labeling:

Class 1 Laser Product
Compliance with 21 CFR
1040.10 and 1040.11

If labeling is not affixed to the module due to size constraints; then rather, labeling is placed on the outside of the shipping box.

This product is not shipped with a power supply.

Caution: use of controls or adjustments or performance of procedures other than those specified herein may result in hazardous radiation exposure.

Certifications

UL	60950-1 (E243407)
TUV	EN60950-1, EN 60825-1, EN 60825-2

Documentation is available upon request.

(1) IEC is a registered trademark of the International Electrotechnical Commission

(2) Within Europe the IEC standard has been adopted as a European Normative standard known as EN 60825, and each European country will have its own version of this standard, for example, the British Standards version known as BS EN 60825. There can be small differences between the different countries versions of EN 60825, and these are in part caused by the process of translating the standard into the native language of that country.

(3) ANSI is a registered trademark of the American National Standards Institute

Note : All information contained in this document is subject to change without notice.